

Copper Chimney Pot

Listed Copper Chimney Pots (manufactured by European Copper, LLC) may be used as an alternate to a factory produced termination cap with Selkirk's MCS Chimney System, provided a Chase Top (constructed as described by the guidelines below) is used for the base and the proper Copper Chimney Pot is installed. See European Copper, LLC installation guidelines to confirm pot use options and limitations for various MCS chimney system diameters.

To Install:

1. Complete installation of Selkirk Chimney system per the main Selkirk Model UT/GT or UTL/GTL installation instructions. Note: finished chimney outlet must extend a minimum of 6" above the chase top while maintaining a minimum 2" airspace clearance to combustibles (see Fig. 1). For Model UTL/GTL a Closure Ring must be installed at the top of the chimney system to protect the insulated wall section (Refer to Main UTL/GTL installation instructions for details).
2. Install Radiation Shields in the chase opening. Radiation Shields can be purchased from Selkirk or can be field fabricated from 28 Ga. Galvanized Steel. Shields must be installed along the entire inside perimeter of the chase opening. Secure Radiation Shields by driving a nail through the tab on the Radiation Shield and into the top surface of the chase. Be sure shield is offset 1/8" from the framed chase opening and extends a minimum of 1/2" beyond the framing. See Fig. 1.
3. Spacer Clips are used to maintain 1/2" clearance between the top of the chase and the chase pan. Clips can be field fabricated or provided by others. Install a minimum of 8 Spacer Clips to the top of chase. (See Figs. 2 & 3).
4. A Custom Chase Top Pan must meet the following requirements (See Figs. 3 & 4):
 1. Be made from non-combustible material.
 2. Have a formed edge to shed water away from opening for pipe.
 3. Overhang the chase top by 1/2"
 4. Have 1" tall edge around all sides
5. Install Custom Chase Pan on top of chase and secure to Spacer Clips. Apply sealant between Chase Pan and Chimney Pipe.
6. Install Storm Collar down over the chimney pipe until it is against the chase top pan. Apply sealant between Storm Collar and pipe to waterproof.
7. Center Copper Pot over chimney pipe and secure Pot to Chase Pan using mounting brackets provided (See Fig. 4).

Fig. 1

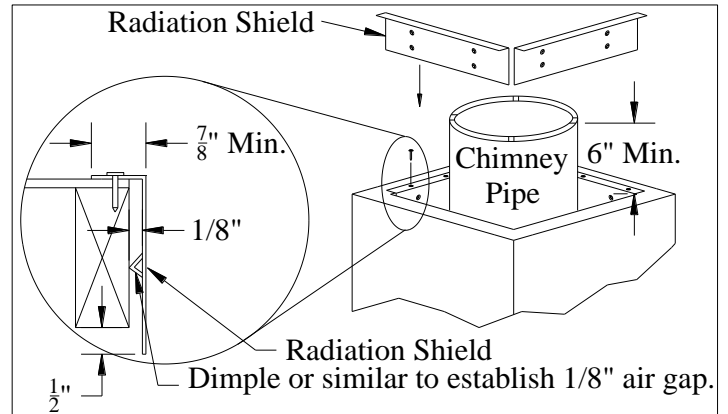

Fig. 2: Spacer Clip Detail

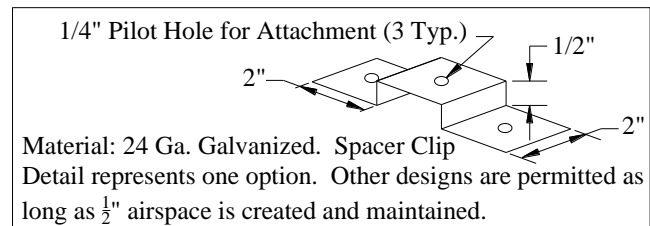

Fig. 3

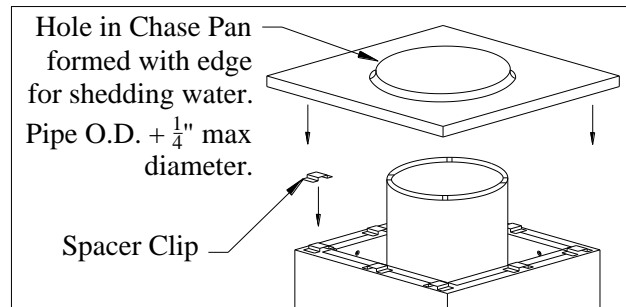

Fig. 4

